

New possibilities at the ESR jet-target

**Thomas Stöhlker
GSI-Darmstadt and IKF, Frankfurt**

- **the jet-target environment**
 - **x-ray spectroscopy**
 - **electron spectroscopy**
 - **recoil ion spectroscopy**
- **the jet target**
- **luminosity and beam lifetimes**
- **photon detector developments**

AP Experiments at the ESR Storage Ring

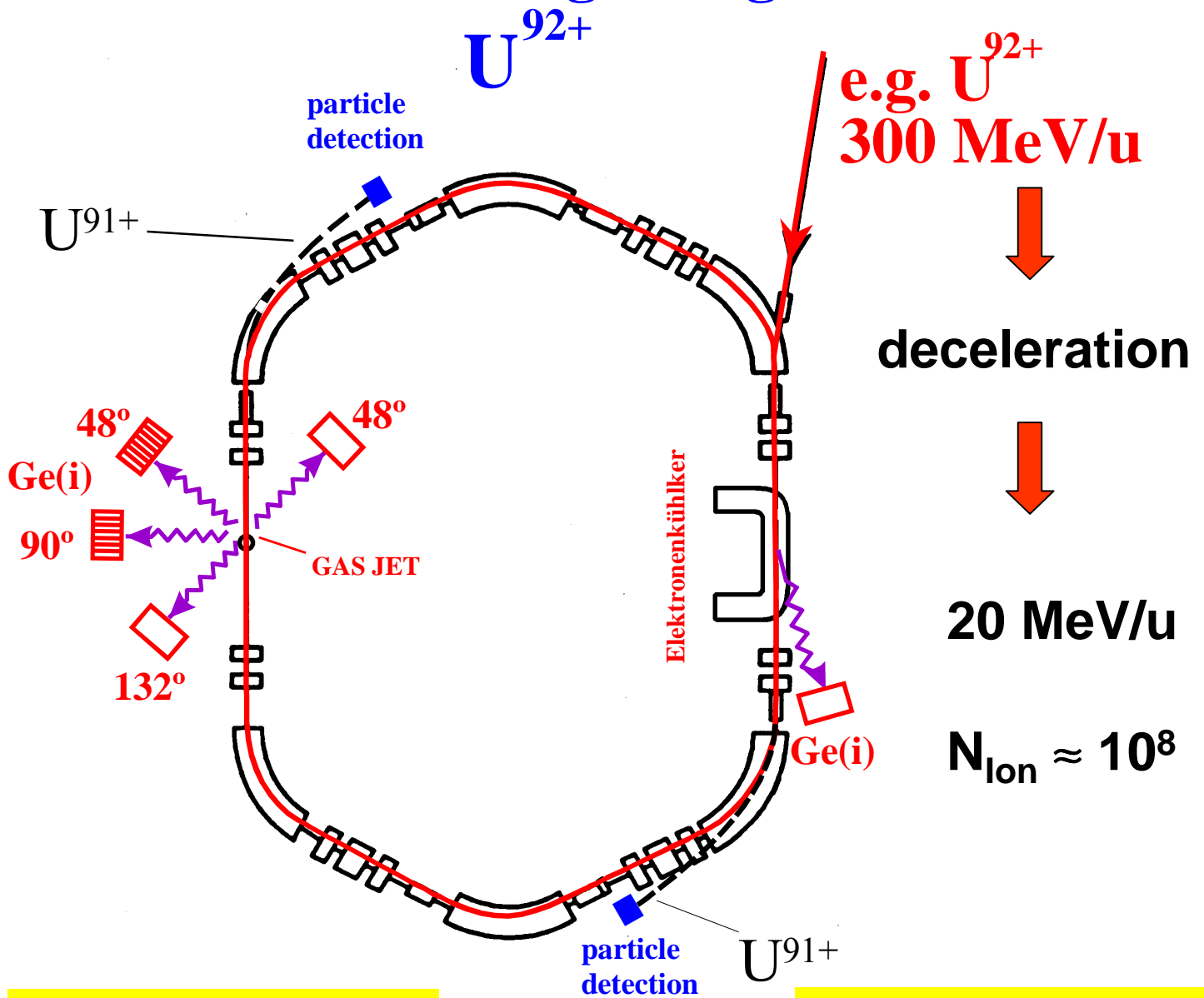

target section

collision dynamics by
X-ray, electron, and
recoil ion spectroscopy

laser experiments

high precision
X-ray spectroscopy

cooler section

recombination studies

laser experiments

X-ray spectroscopy

the new jet-target environment

electron spectrometer (permanent installation)

more flexible installation of the target chamber
(can get exchanged in typical time intervals of one to two years)

Bolometer detector systems can get installed

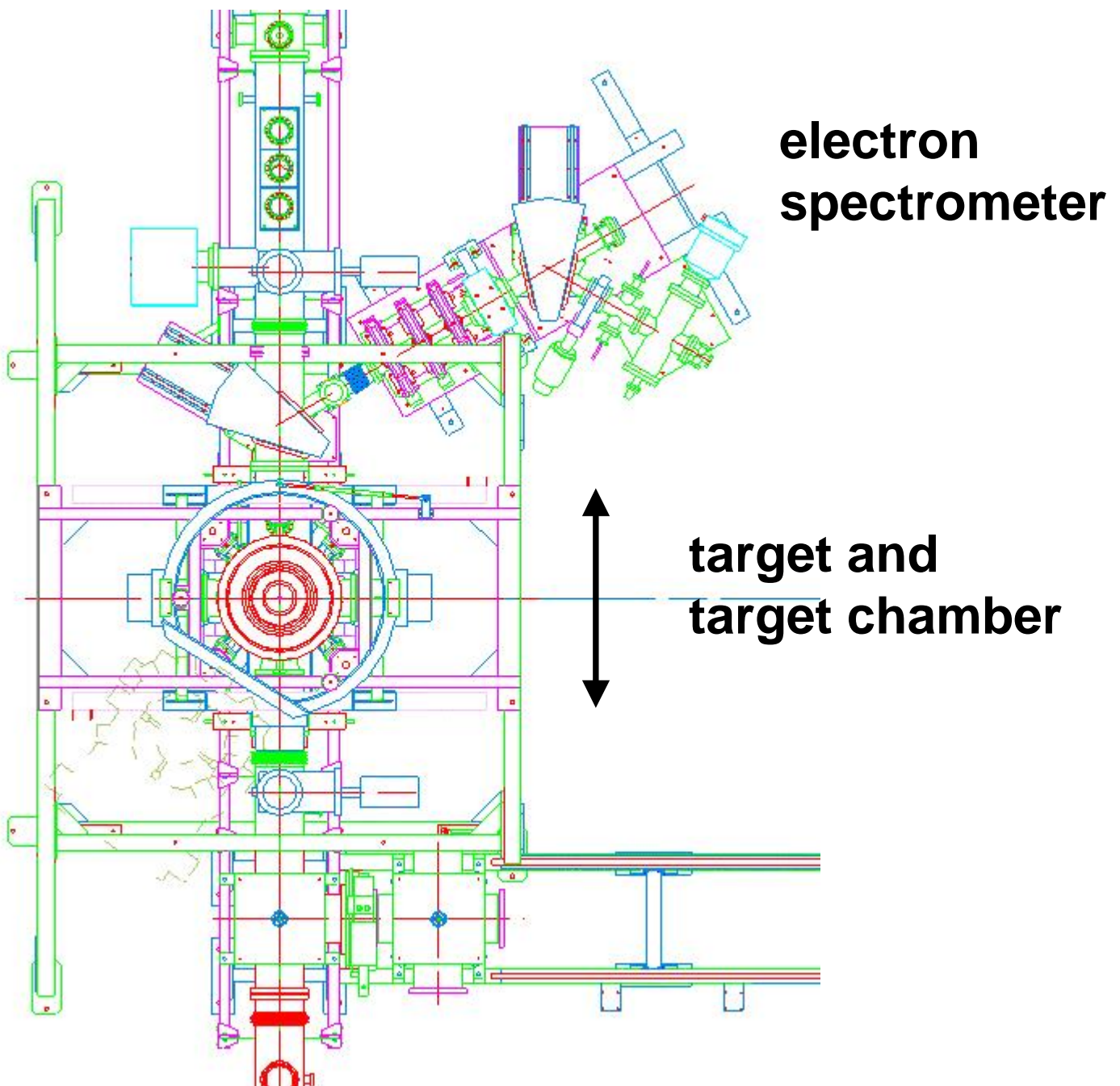

Current setup at the target

X-Ray Detector Chamber Combined with 0-deg Electron Spectrometer

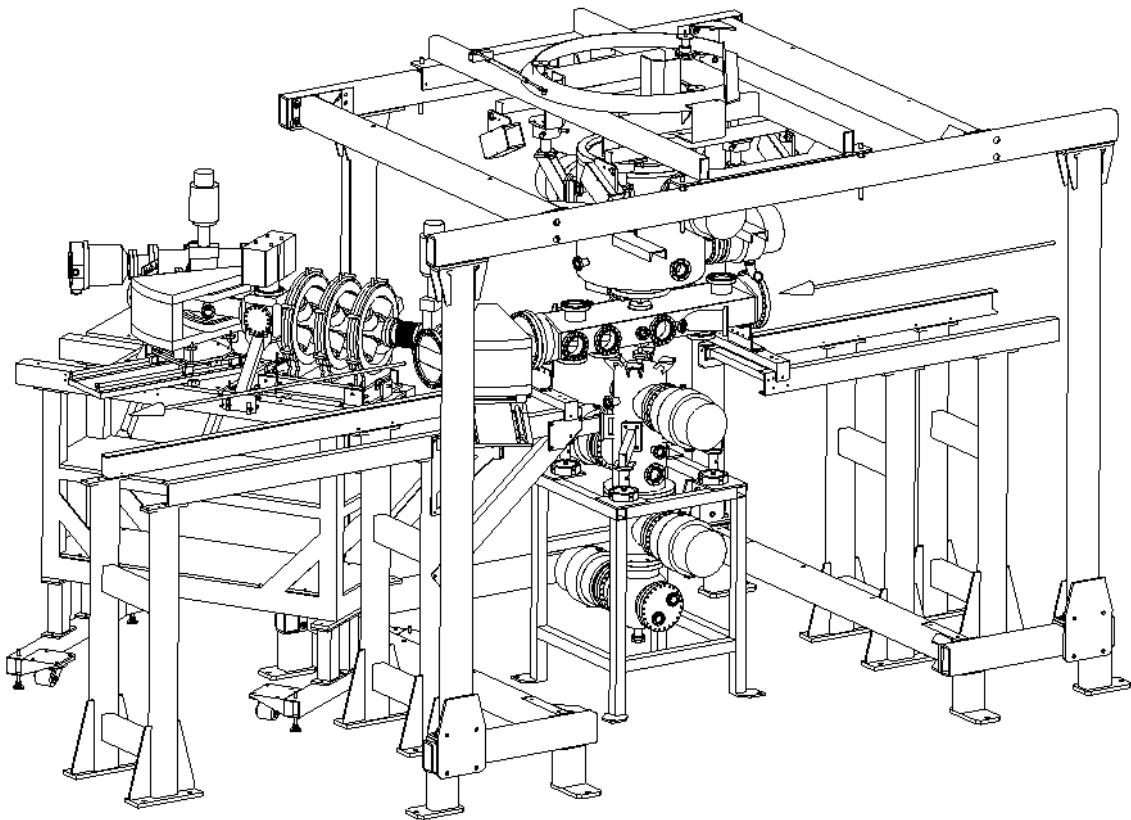

**0-deg Electron Spectrometer:
compare presentation of S. Hagmann**

X-Ray Detector Chamber Currently Installed

(Compare presentation by A. Warczak)

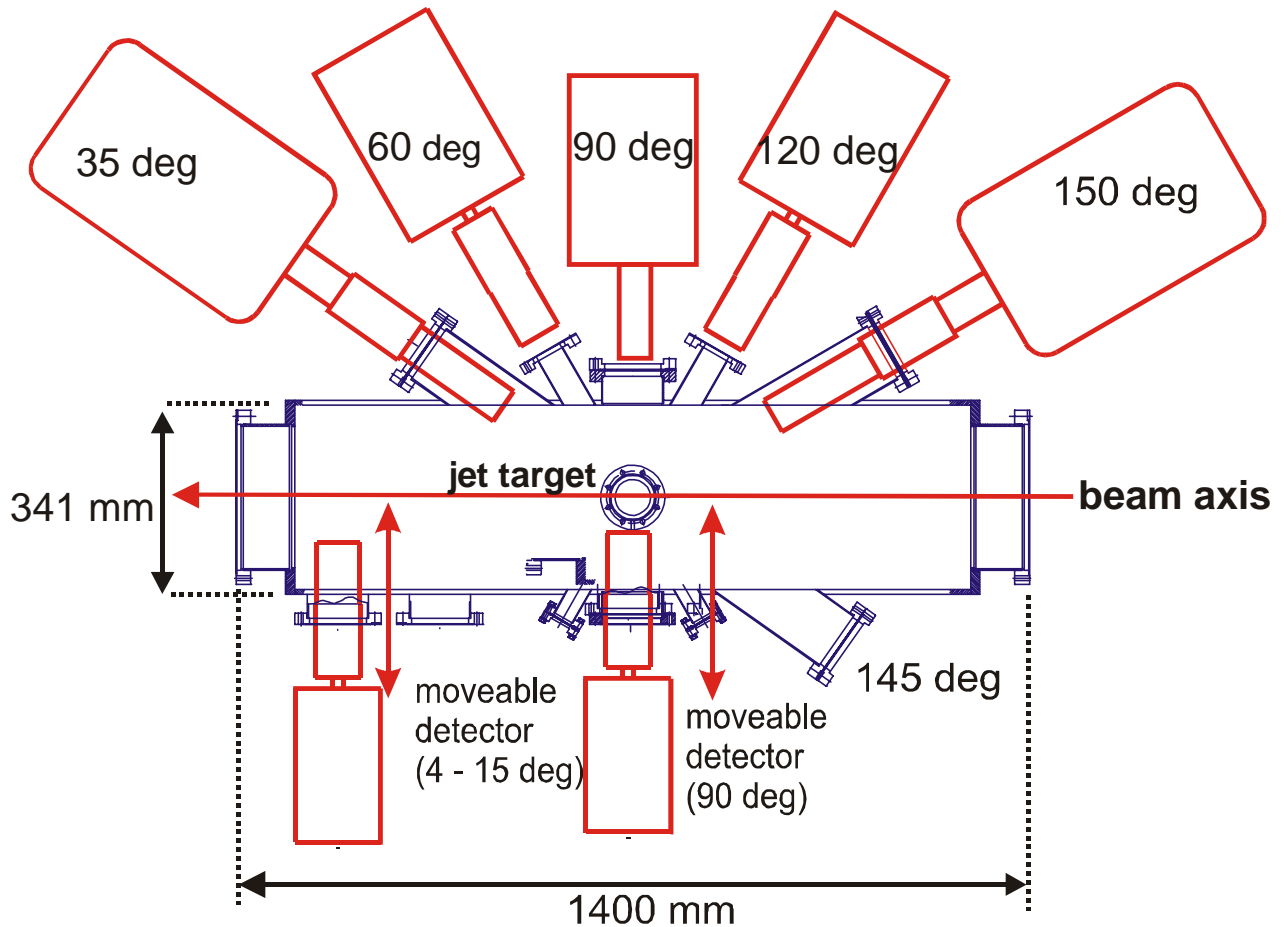

- Photon angular correlation studies
- 0-deg photon spectroscopy
- X-X coincidence experiments
- photon polarization experiments
- precision photon spectroscopy, crystal spectrometer, calorimeter

Recoil Ion Chamber Combined with 0-deg Electron Spectrometer

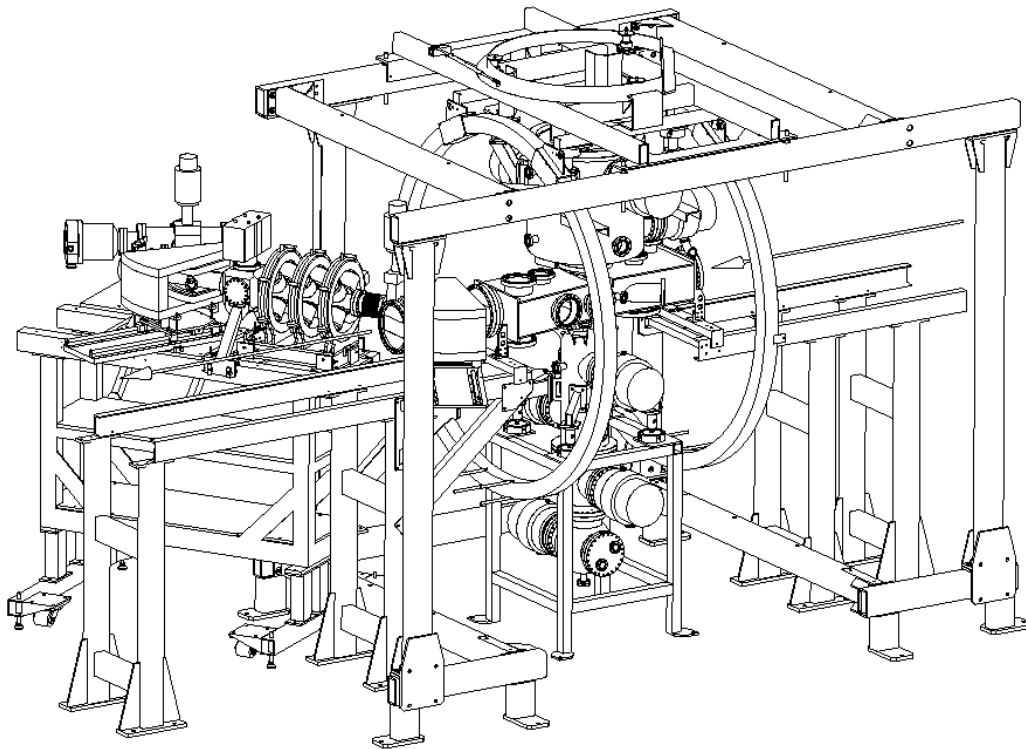

Recoil ion spectrometer:

A longitudinal **B** field and a electrostatic **E** field will allow to detect low momentum target electrons and target recoil ions

(compare presentation of R. Moshammer)

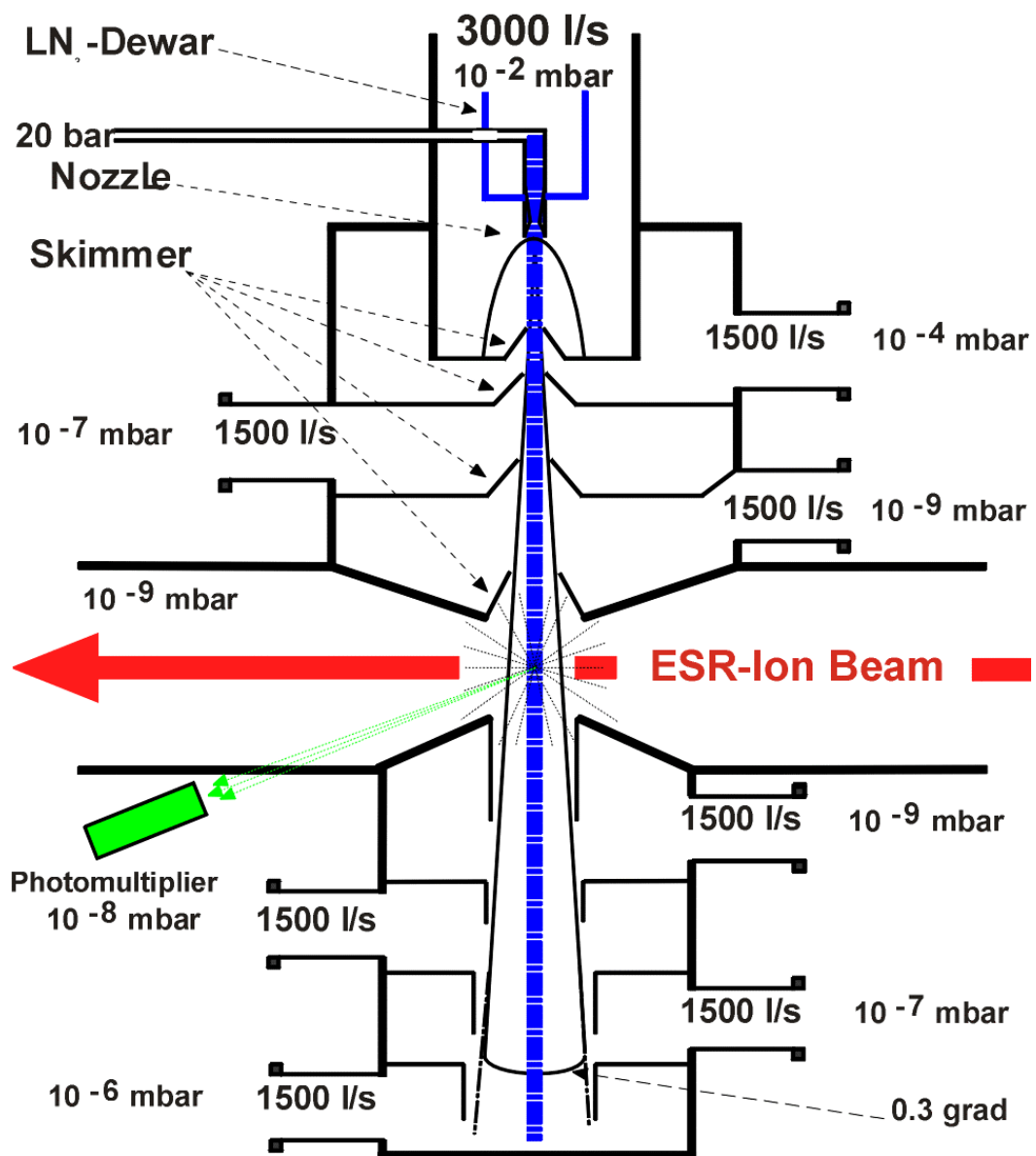

Target densities

10¹² – 10¹⁴ p/cm³

H. Reich et al., Nucl. Phys. A 626 (1997) 417c.

Target densities

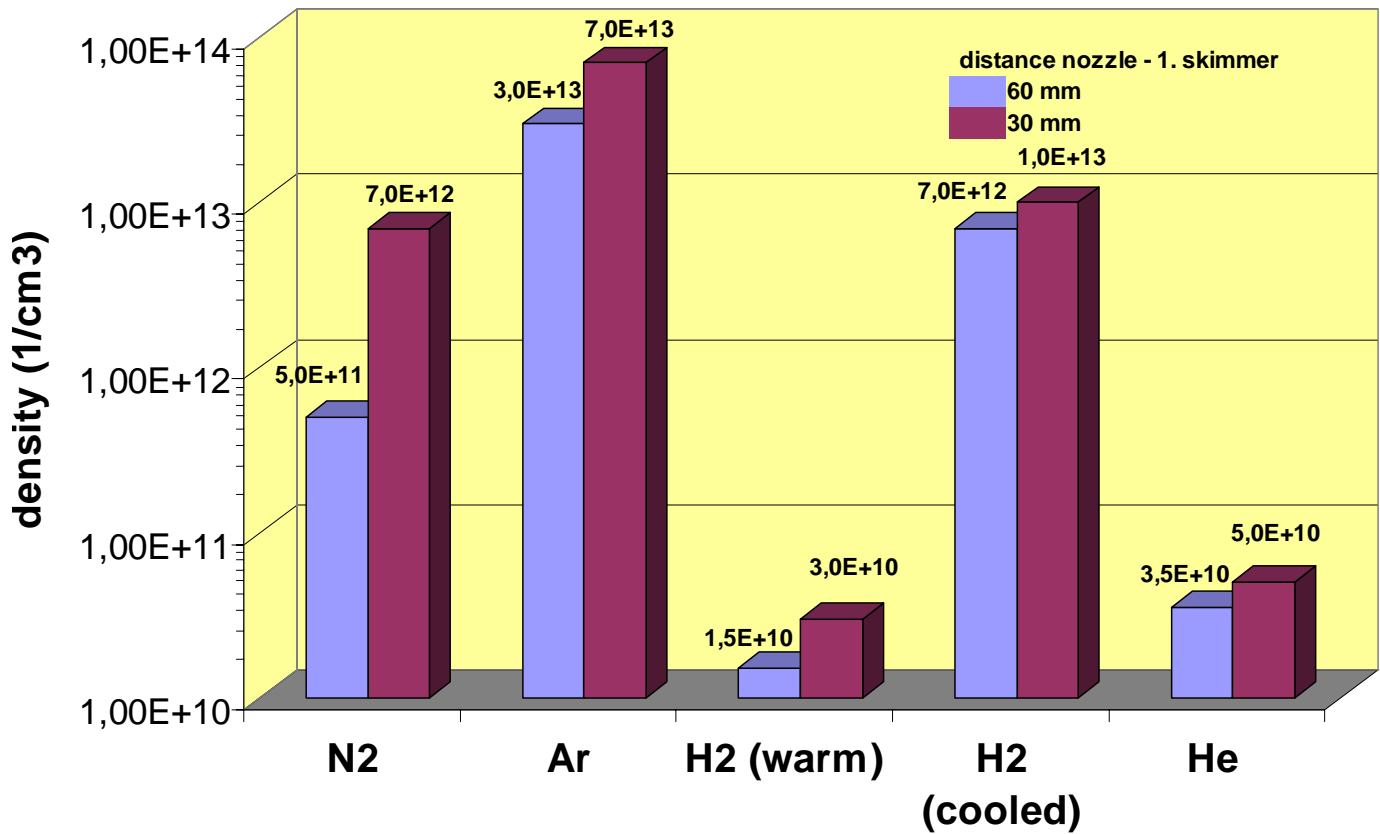

by cooling to LN₂ temperatures a density increase from $\approx 10^{10}$ p/cm³ to $\approx 10^{13}$ p/cm³ has been achieved for H₂

A. Krämer et al., NIM B174, 205 (2001)

Future modifications

- Lower temperatures
- Variable/smaller jet-beam diameter (5mm to 1mm)

Radiative Electron Capture (REC)

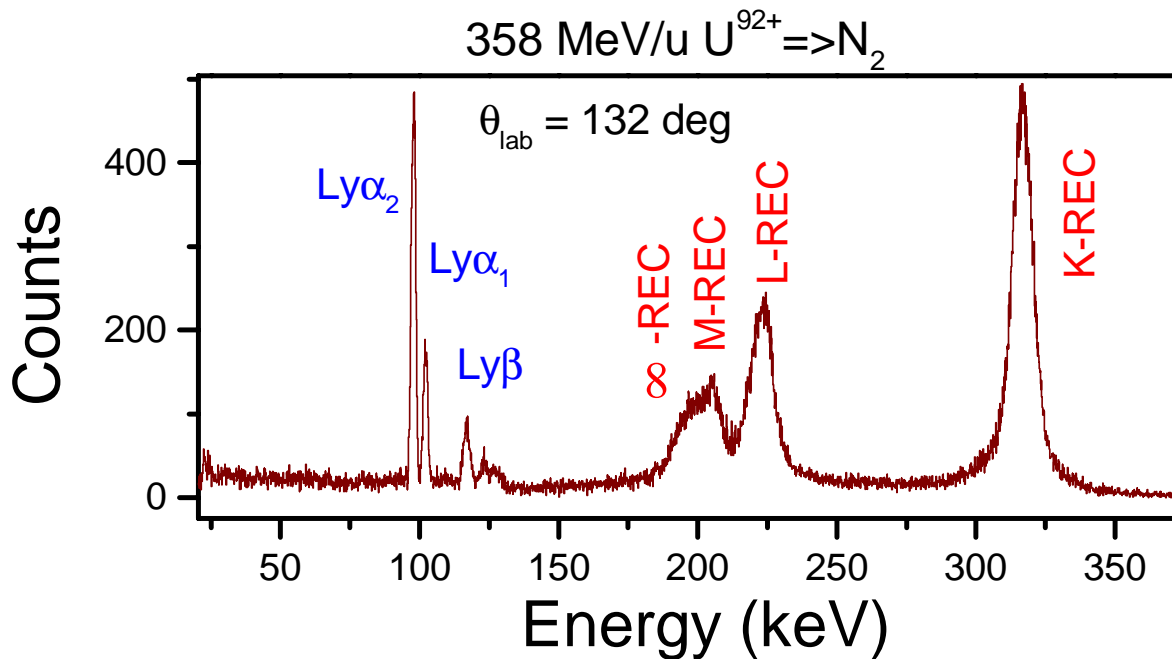

projectile system

$$E_{REC} = E_K + m_e c^2 (\gamma - 1) + \gamma (p_i v_0 - E_T^B)$$

E_K : binding energy in the projectile

E_T^B : binding energy in the target

p_i : electron momentum in the target

v_0 : projectile velocity

$m_e c^2 (\gamma - 1)$: kinetic energy

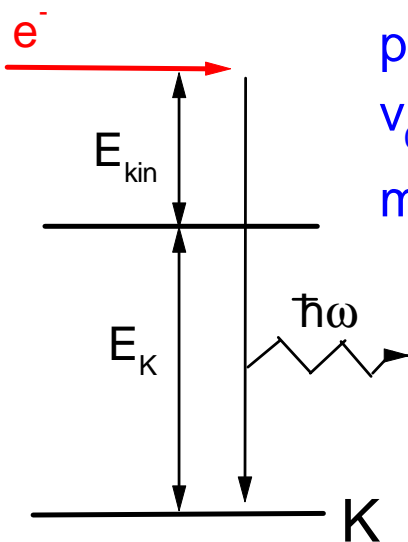

test experiment with a H₂-target:
bare Pb ions at 25 MeV/u

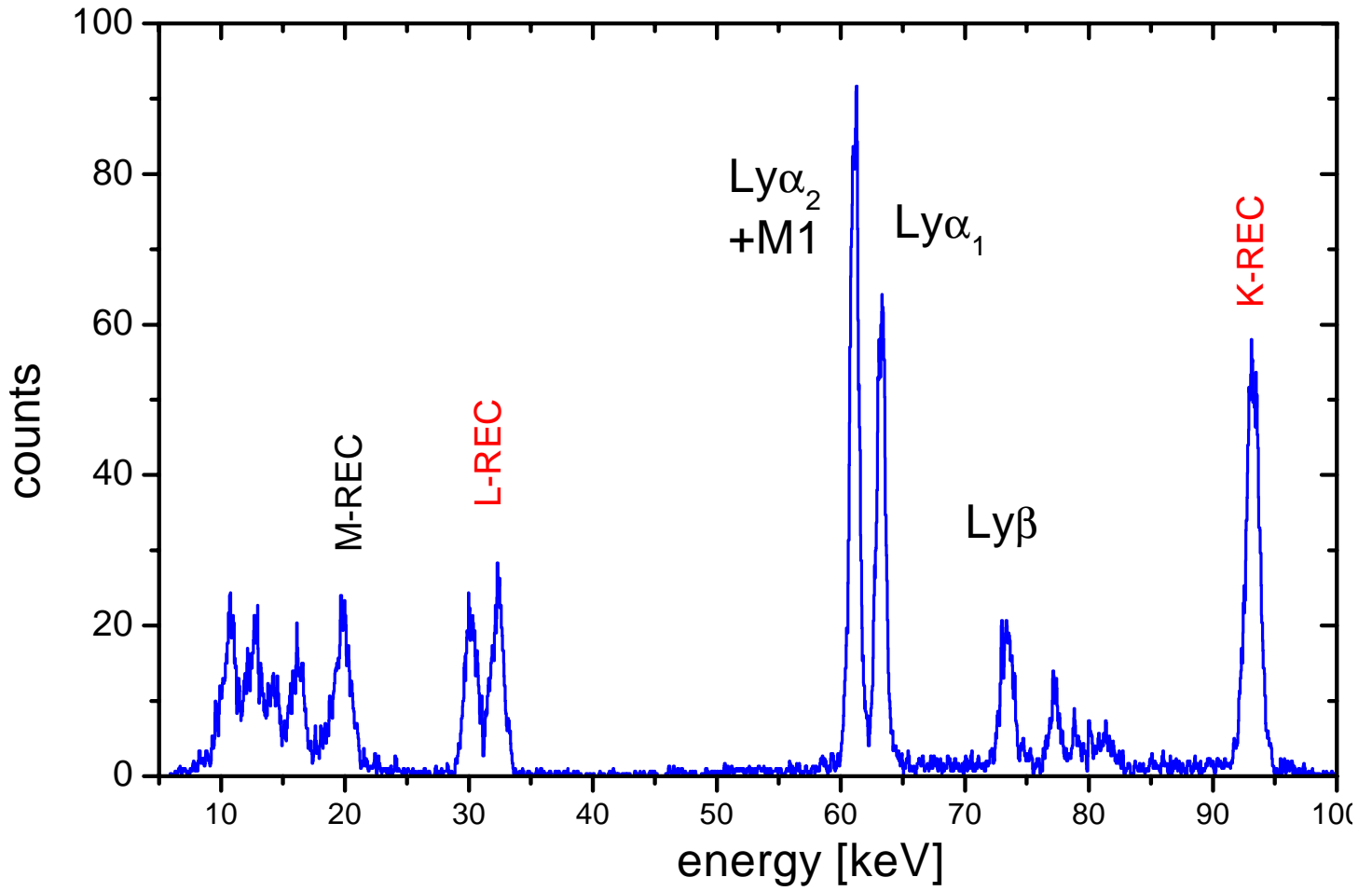

A. Krämer et al., NIM B174, 205 (2001)

Beam life times with gasjet target

the beam lifetime (τ) is connected to the charge-exchange cross-section (σ) by the relation

$$\lambda = \frac{1}{\tau} = \rho \times \sigma \times f$$

λ denotes the charge exchange rate

ρ the effective target thickness ($1/\text{cm}^2$)

f the revolution frequency of the circulating ion beam

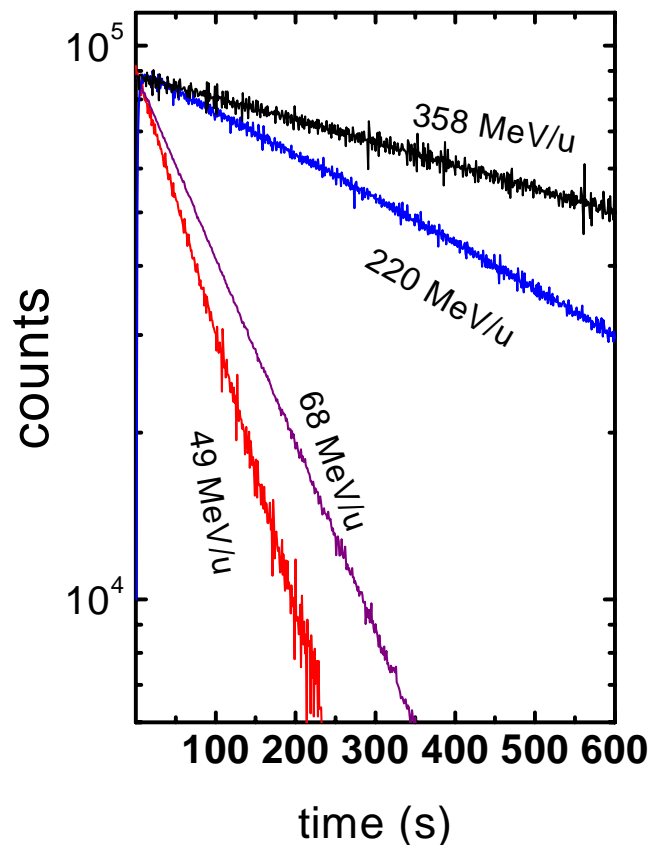
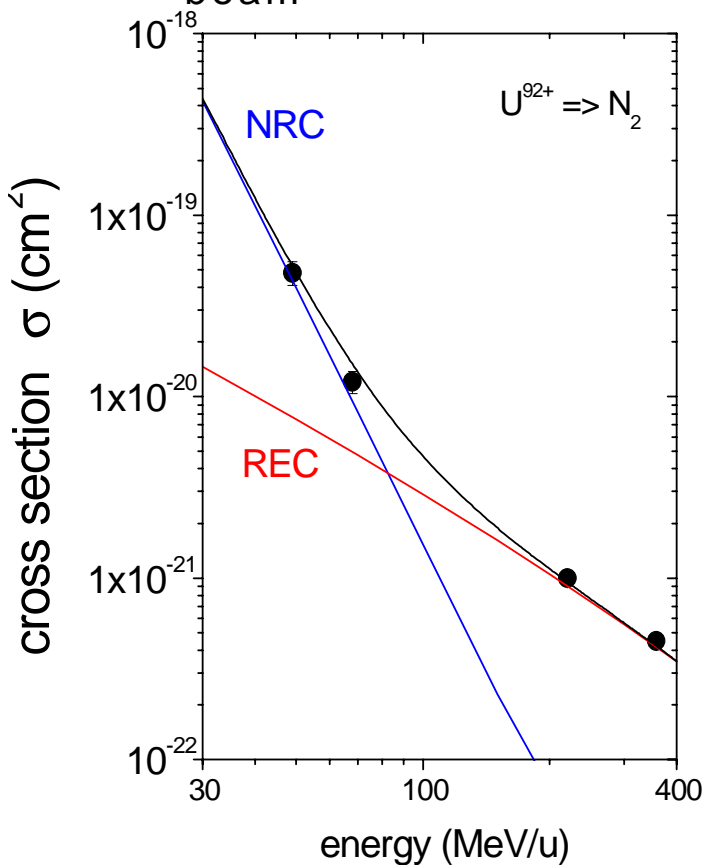

for decelerated ions, RR in the cooler section contributes considerably to beam losses

Beam life times with gasjet target

the beam lifetime (τ) is connected to the charge-exchange cross-section (σ) by the relation

$$\lambda = \frac{1}{\tau} = \rho \times \sigma \times f$$

λ denotes the charge exchange rate

ρ the effective target thickness ($1/\text{cm}^2$)

f the revolution frequency of the circulating ion beam

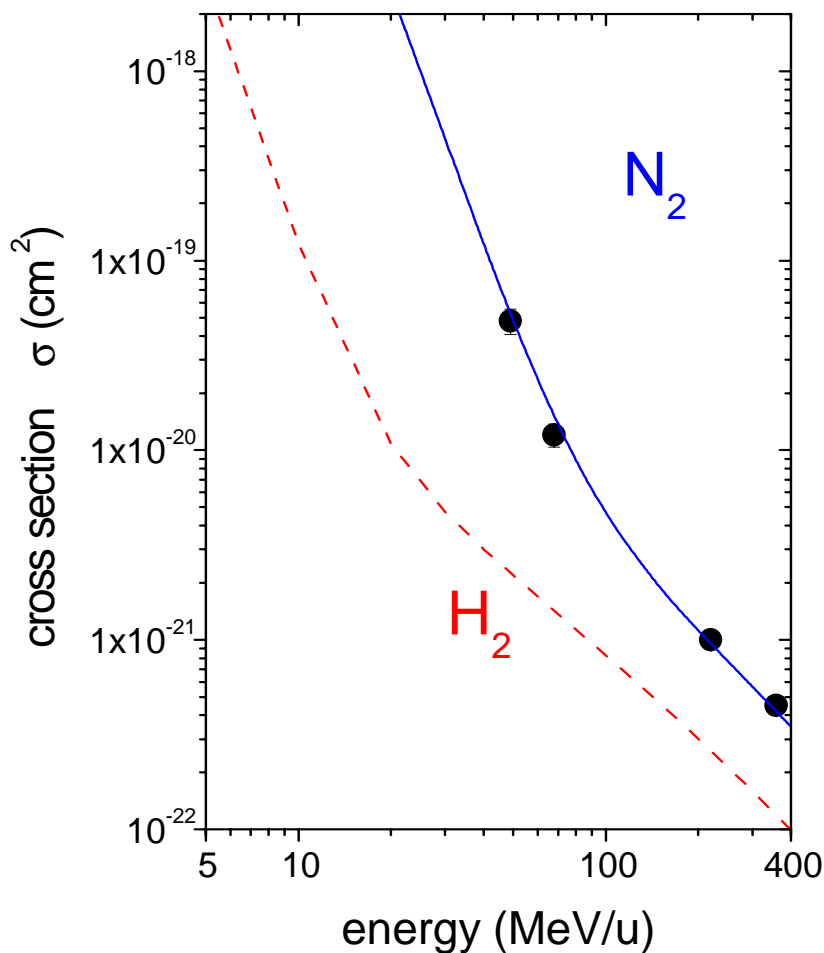

The Status of the Deceleration Technique at the ESR

1995: Deceleration down to **50 MeV/u** routinely available

1999: First experiment with bare high-Z ions (Pb^{82+}) at **25 MeV/u**

2000: Deceleration of U^{92+} down to **9 MeV/u** (M. Steck et al.)

Intensity Increase at the ESR

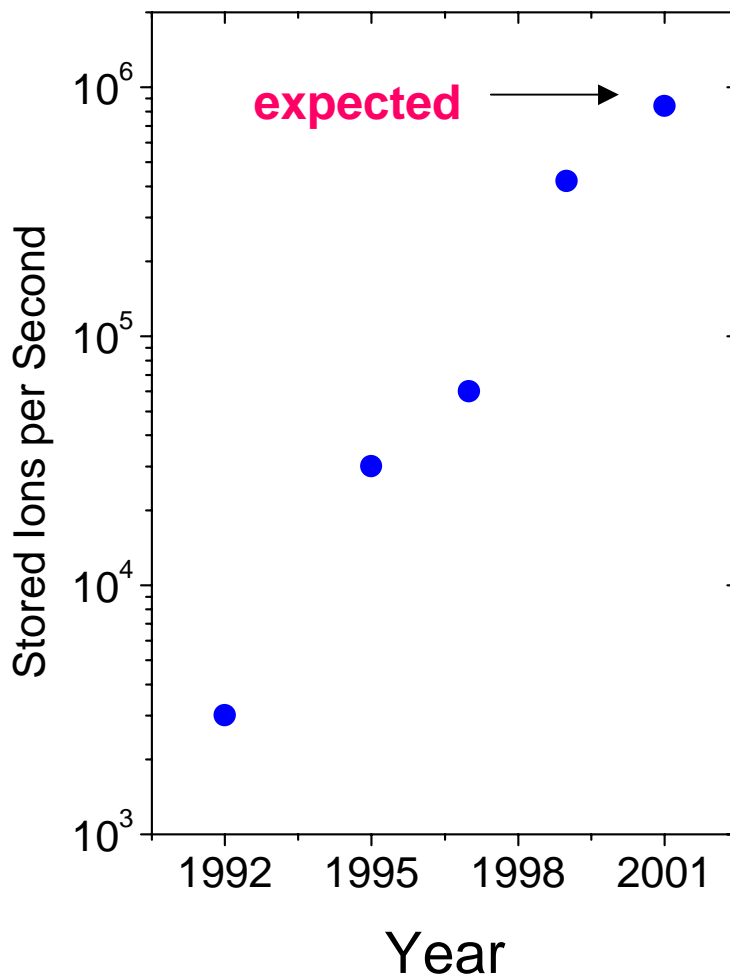

*Increase
by more
than
two-orders
of magnitude*

Experiment cycle at the target

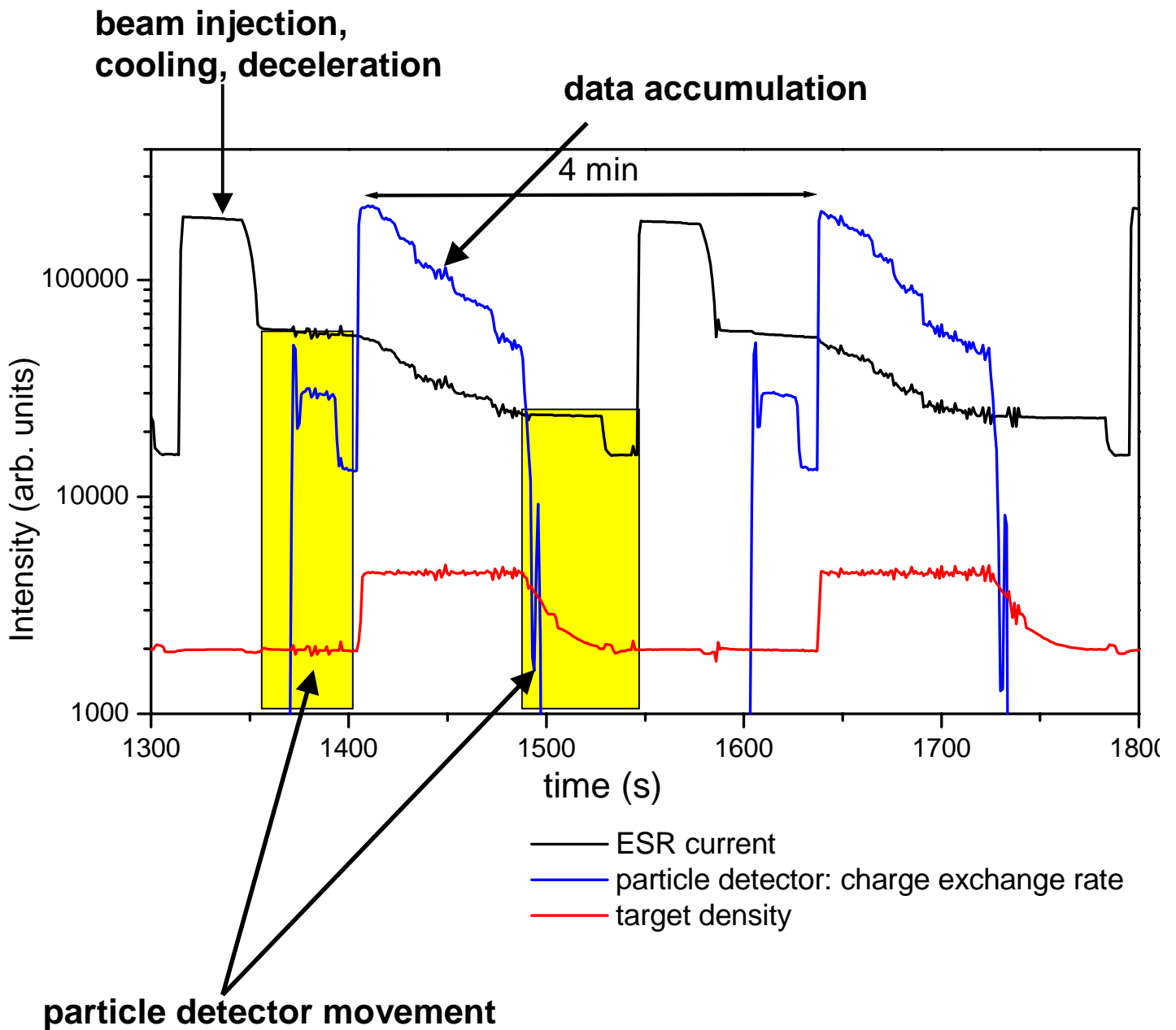

By faster particle detector movement, the overall efficiency can be improved by up to a factor of two.

Few-Electron High-Z Ion Beams at Relativistic Energies (e.g. 300 to 400 MeV/u)

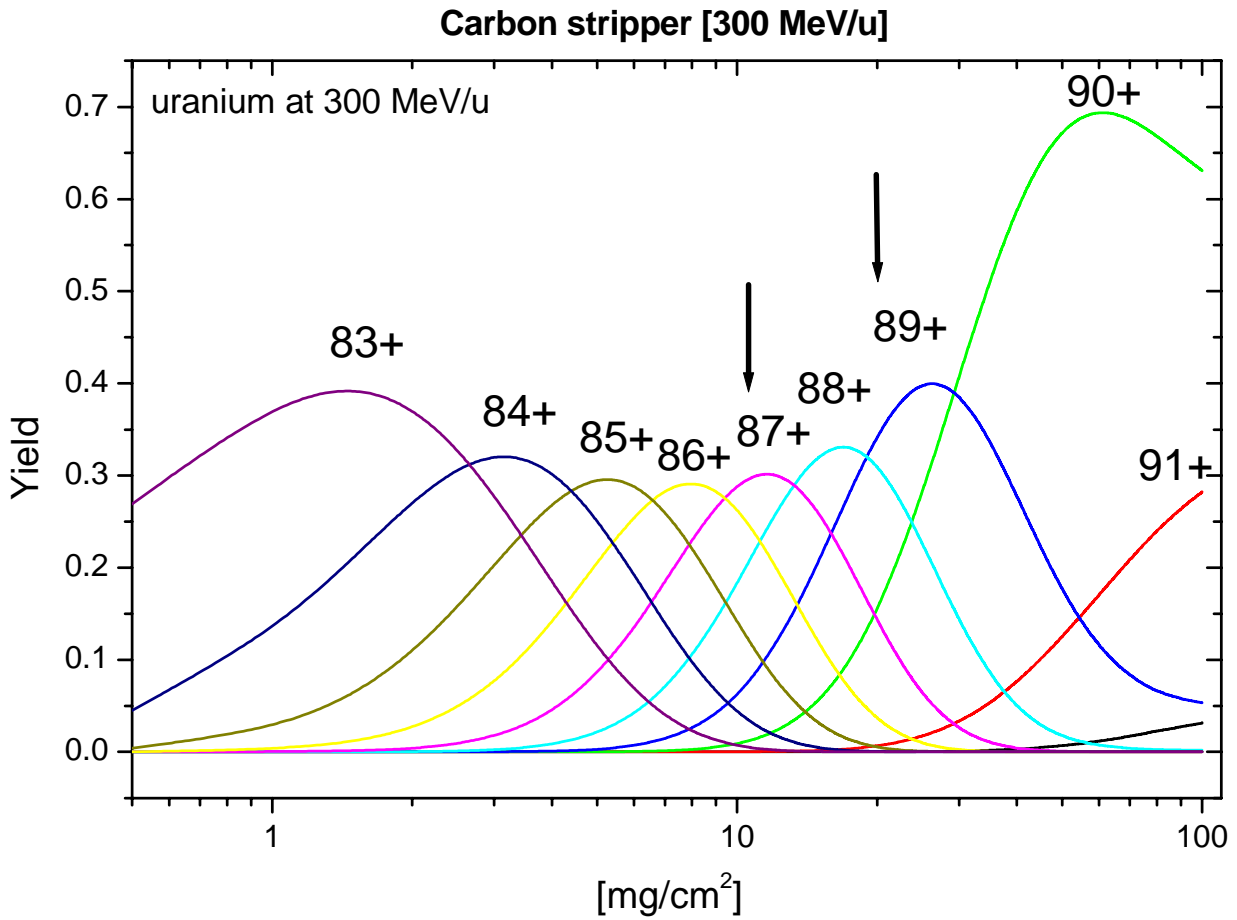

K-shell vacancy production of lithium-like uranium studied at the ESR

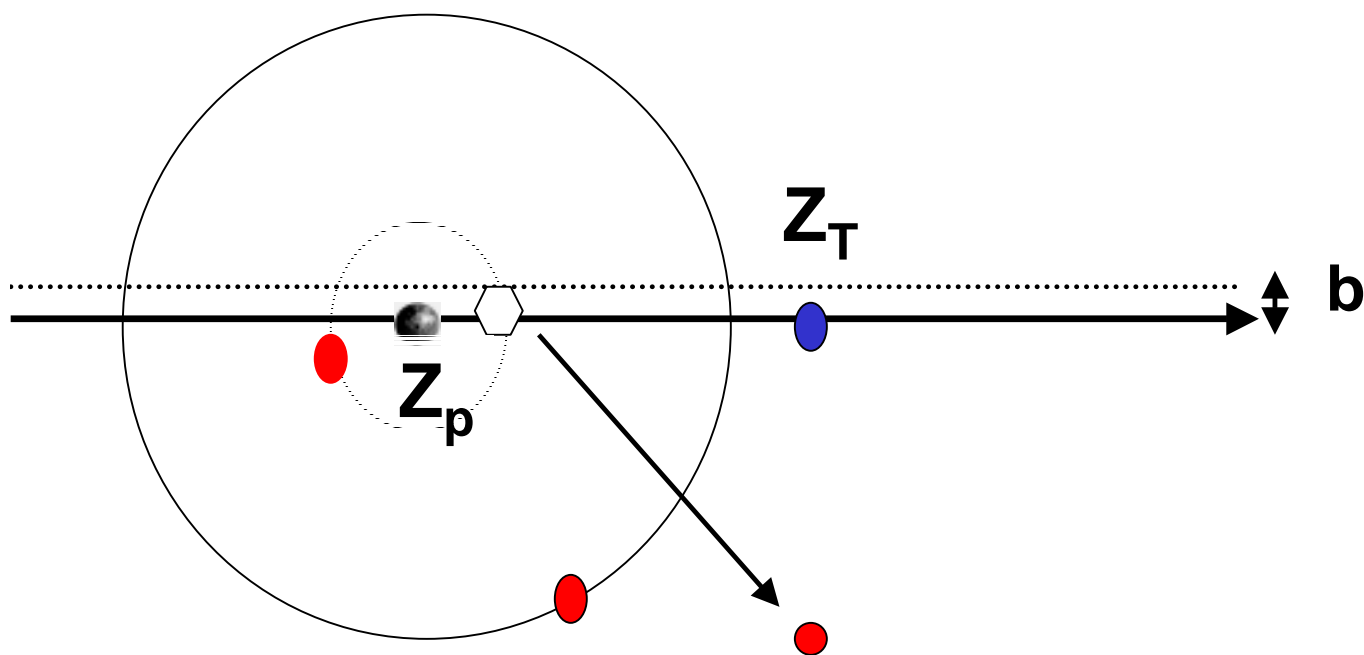
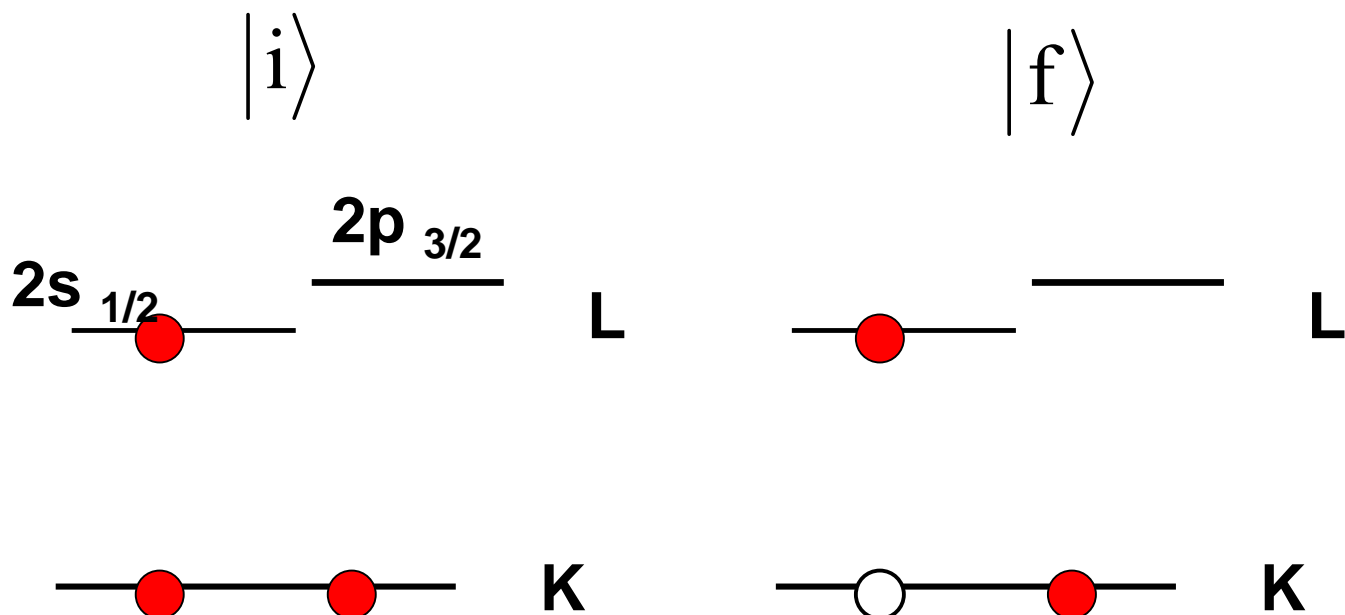

U90+

$[1s_{1/2}, 2p_{3/2}]^1P_1$
 $[1s_{1/2}, 2p_{3/2}]^3P_2$

$[1s_{1/2}, 2s_{1/2}]^1S_0$
 $[1s_{1/2}, 2s_{1/2}]^3S_1$

$[1s_{1/2}, 2p_{1/2}]^3P_0$
 $[1s_{1/2}, 2p_{1/2}]^3P_1$

2E1

M1

$[1s_{1/2}, 1s_{1/2}]^1S_0$

M 1

0-deg photon spectroscopy

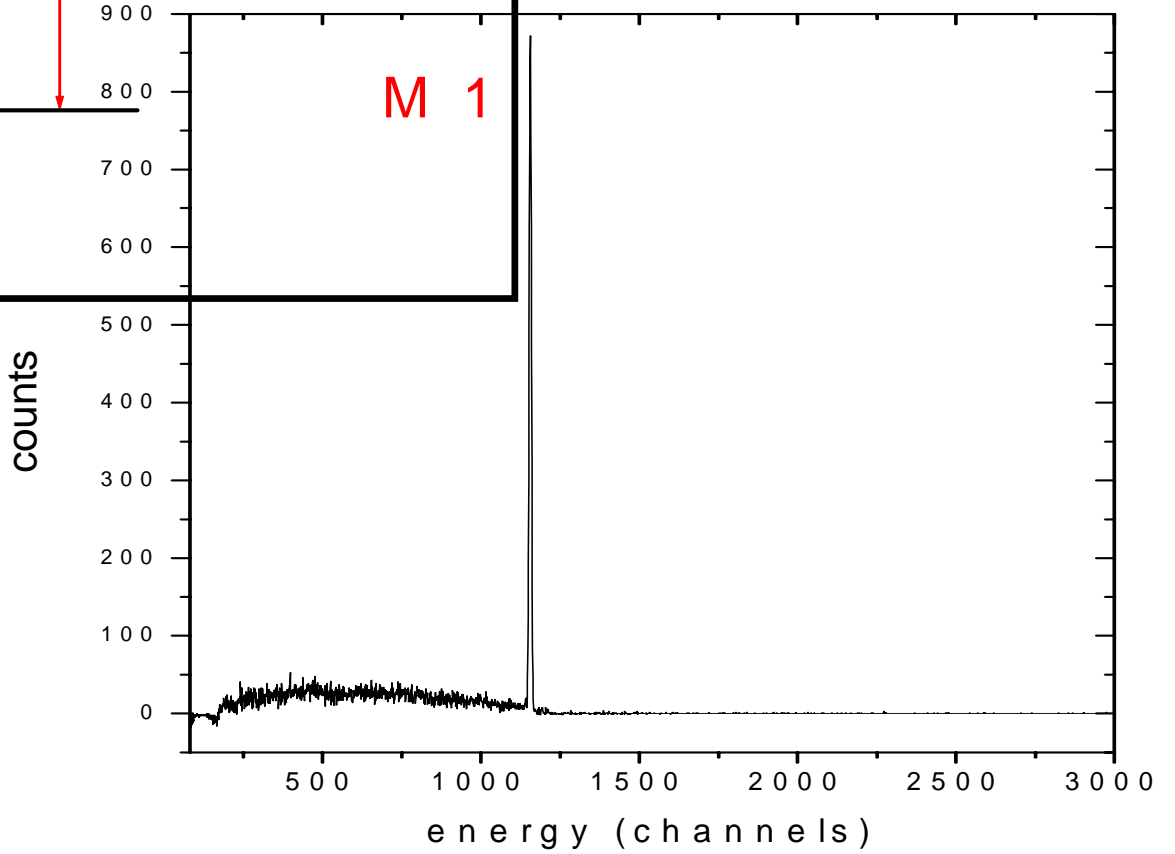

Photon detector/spectrometer development

- calorimeter detector

(P. Egelhof)

- crystal spectrometer

(H. Beyer)

- position sensitive gas detectors

(D. Liesen)

- position sensitive Ge(i) detectors

(Th. Stöhlker)

Development of a Bolometer System for the High Energy Regime

Detection of Phonons instead of Electrons

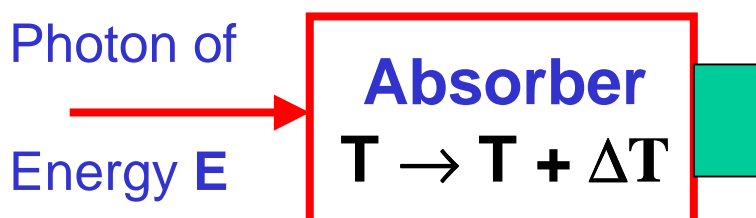

Thermometer
 $\Delta T = E / C$



Heat capacity: $C = c \cdot m$
 $C \sim T^3$

Specific heat capacity : c

Detector mass: m



A. Bleile et al., NIM A 444, 488 (2000)

Detector operates at temperatures of 50 mK

detector: Pb-absorber ($V = 0.2 \text{ mm}^2 \times 47 \text{ }\mu\text{m}$)

energy resolution for $E_\gamma = 59.6 \text{ keV}$:

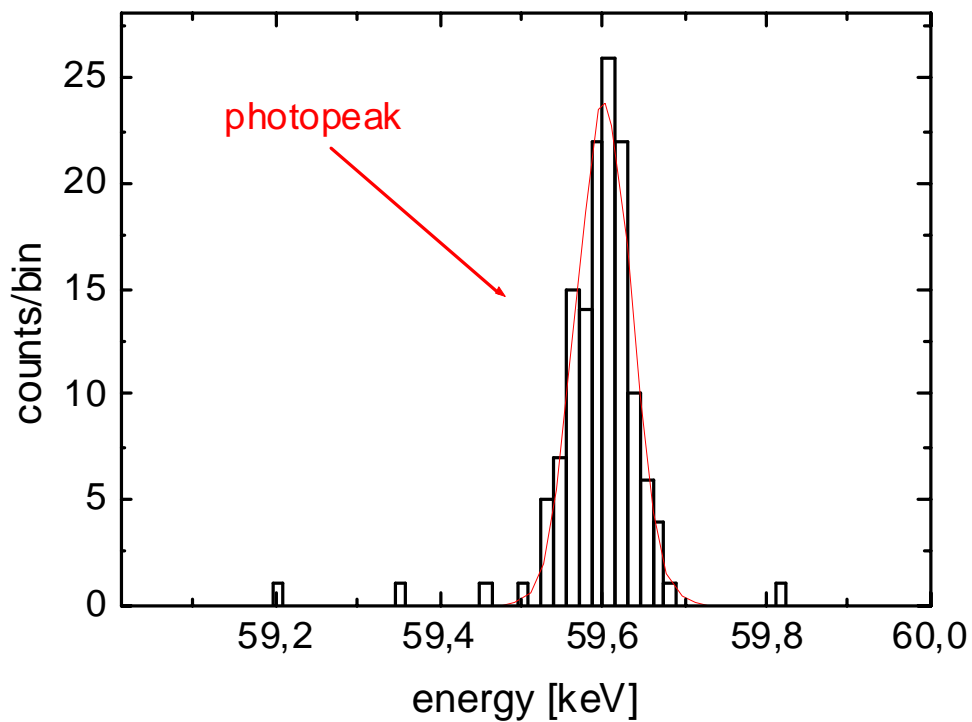

$$\Delta E = 65 \text{ eV}$$

P. Egelhof, priv. communication (2001)

(theoretical limit for conventional
Si-semiconductor detector: $\Delta E \geq 350 \text{ eV}$)

Calorimeter for 1s-Lamb Shift Experiments

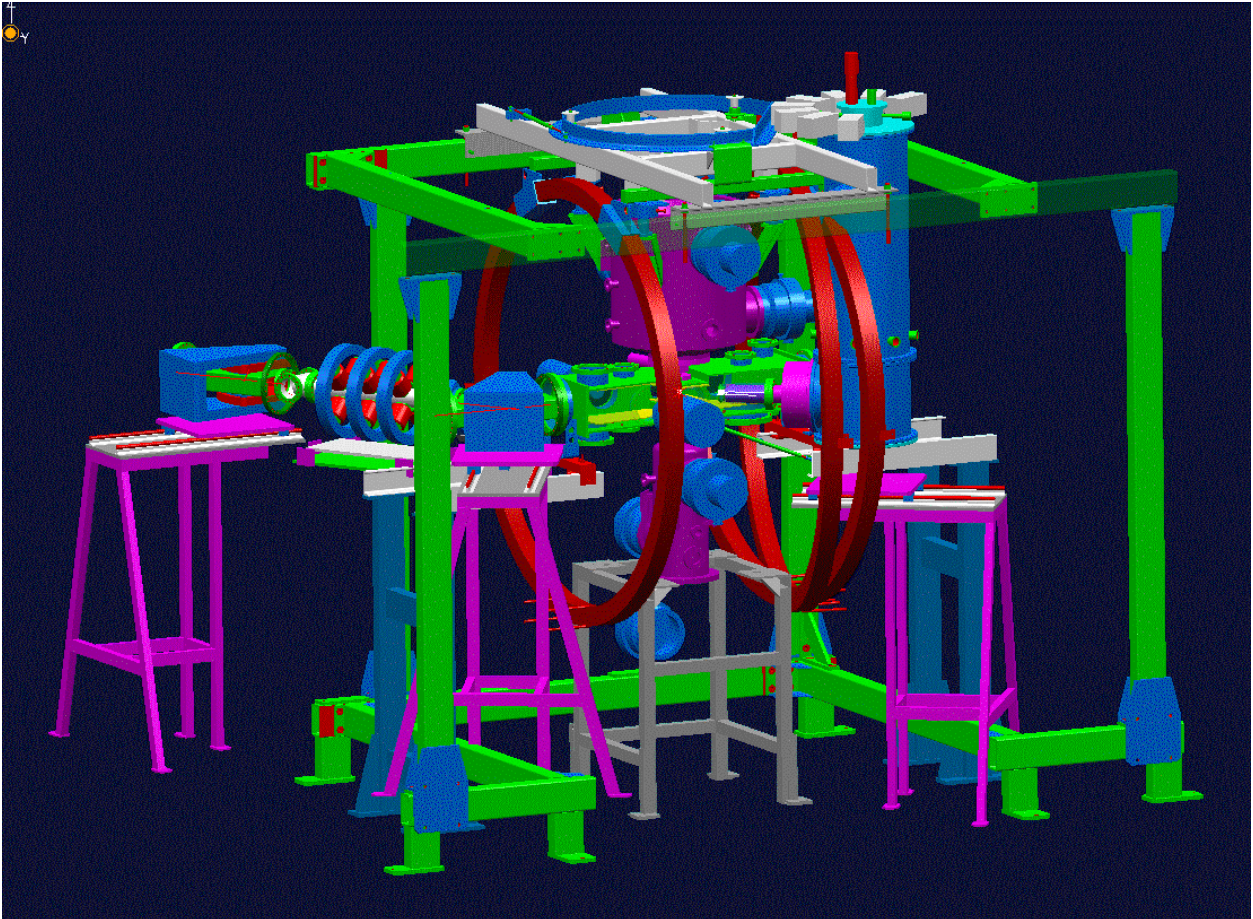

A. Bleile et al., NIM A 444, 488 (2000)

Calorimeter for 1 to 20 keV range*



View port for calorimeter. The dimensions of the light blue cylinder correspond to the one of the cryodetector.*

*E. Silver et al., *Astrophysical Journal* 541, 405 (2000)

Position Sensitive Ge(i) Detectors

Micro-Strip Germanium Detector
Development:

Energy Resolved X-Ray Imaging, Timing,
Multi-Hit Capability

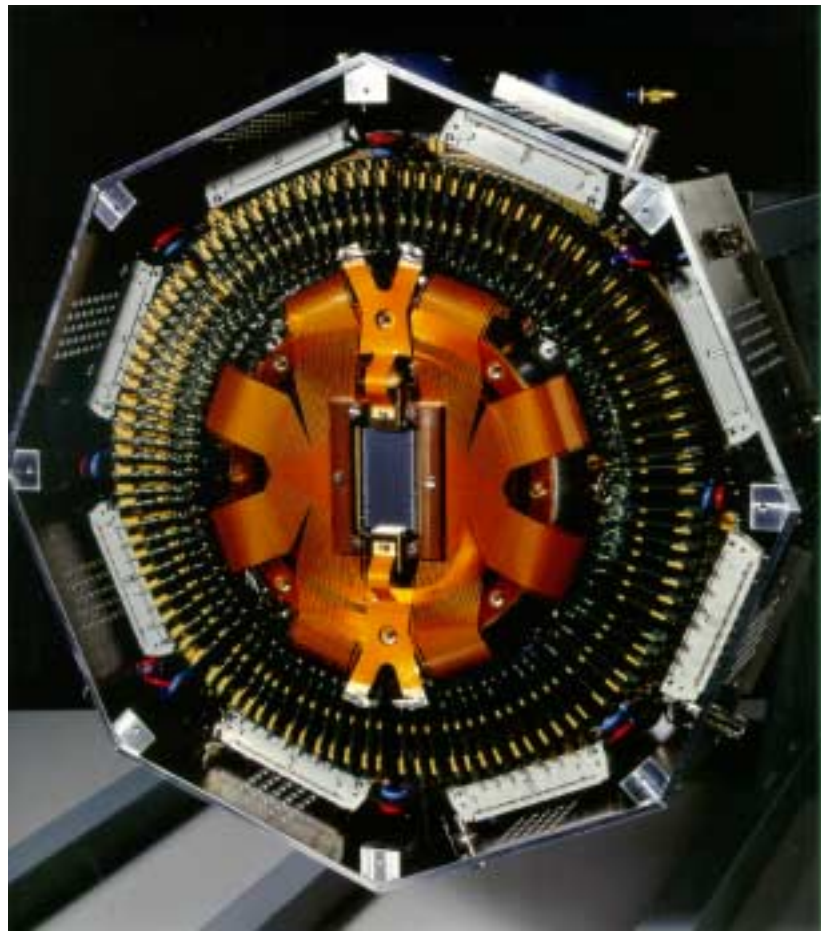
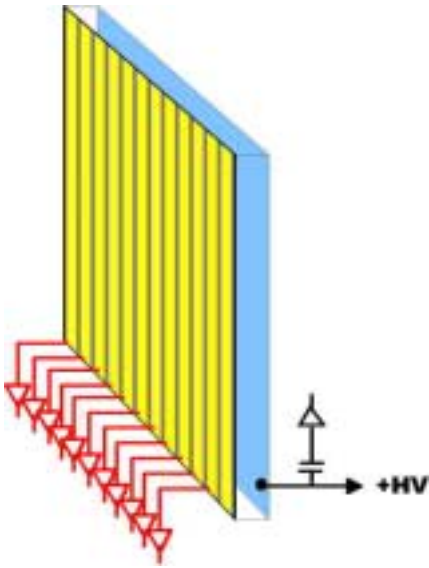

- crystal spectrometer
- Doppler tuned
- polarization studies

D. Protic et al., IEEE in print (2001)

Th. Stöhlker et al., GSI Scientific Report 1999, p. 206

Micro-Strip Germanium Detectors for Position Sensitive X-ray Spectroscopy

Energy

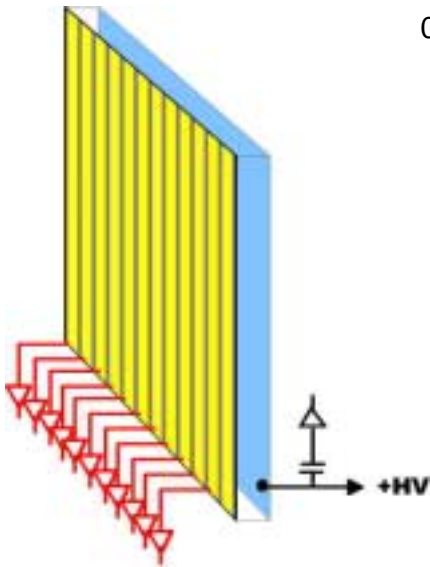
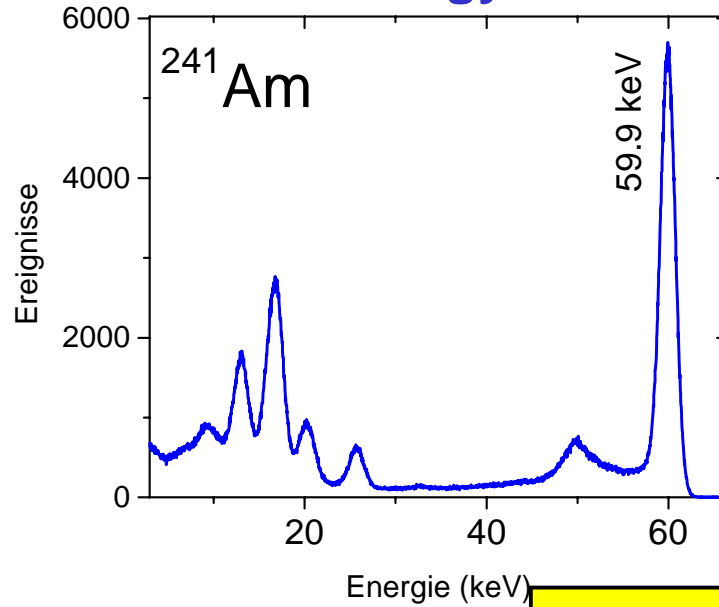

Energy resolution
1.6 keV @ 60 keV

Position resolution
200 μm

Time resolution
50 ns

Timing

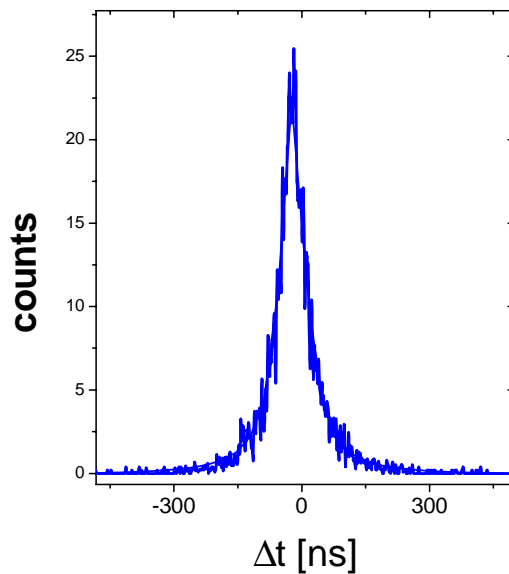

Transmission crystal spectrometer

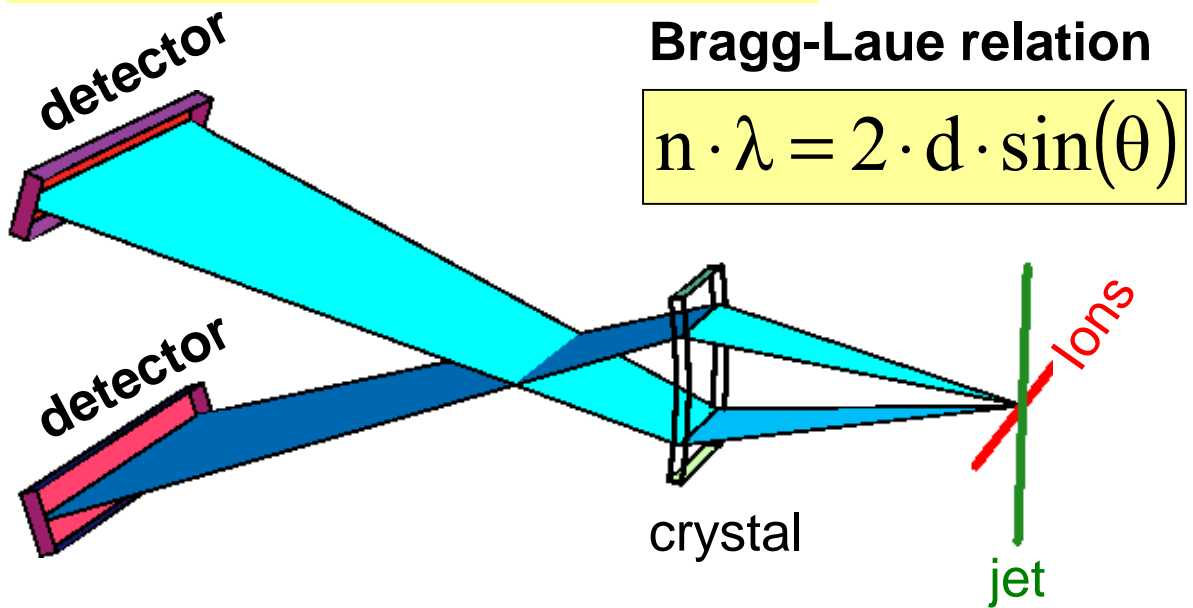

(compare presentation by H.F. Beyer)

